



**INSTALLATION GUIDE FOR THE
OPTIFLAME ELECTRIC
FIREPLACE**

MODEL NUMBERS:

BF33ST/DX

BF39ST/DX

HBI39ST/DX

BF45ST/DX

HBI45ST/DX

CONTENTS

PAGE 1	Listings and Code Approvals
PAGE 1	Model Specifications
PAGE 1	Step-by-Step Installation
PAGE 2	Section A Framing
PAGE 2	Section B Recommended Power Supply Wire Specifications
PAGE 2	Recommended Wire and Fusing Requirements
PAGE 3	Voltage Selector Switch Location
PAGE 3	Mounting Flanges
PAGE 4	Section C Factory Setting Wiring 240 Volt (Without Main Power Wall Switch)
PAGE 5	Factory Setting Wiring 120 volt (Without Main Power Wall Switch)
PAGE 6 - 7	Section D Main Power Wall Switch Wiring for 240 Volt
PAGE 8 - 9	Main Power Wall Switch Wiring for 120 Volt
PAGE 10 - 11	Section E Heater Wall Switch Wiring for 120/240 Volt
PAGE 12 - 13	Wall Mounted Thermostat Wiring for 120/240 Volt
PAGE 14 - 15	Flame Override Switch Wiring for 120/240 Volt
PAGE 16 - 18	Section F Wiring Diagrams

LISTINGS AND CODE APPROVALS

The BF series fireplaces have been tested in accordance with the UL 2021 and CSA C22.2 No. 46 standards for fixed and location-dedicated electric room heaters.

MODEL SPECIFICATIONS

Model Number	Description	Voltage Volts	Rated Power Watts	Remote Control	Wall Thermostat	Refractory Brick Look	AMPS 120Volt	AMPS 208Volt	AMPS 240Volt
BF33ST	33" Standard	120/208/240	1440/2100/2700	Option	Option	N/A	12.0	10.10	11.25
BF33DX	33" Deluxe	120/208/240	1440/2100/2700	Option	Option	Included	12.0	10.10	11.25
BF39ST	39" Standard	120/208/240	1440/2100/2700	Option	Option	N/A	12.0	10.10	11.25
BF39DX	39" Deluxe	120/208/240	1440/2100/2700	Option	Option	Included	12.0	10.10	11.25
BF45ST	45" Standard	120/208/240	1440/2100/2700	Option	Option	N/A	12.0	10.10	11.25
BF45DX	45" Deluxe	120/208/240	1440/2100/2700	Option	Option	Included	12.0	10.10	11.25

NOTE: Power ratings shown include the light bulbs and motor (275 watts)

WARNING:

The installation of the fireplace unit must comply with the applicable Local and/or National Electrical Codes and utility requirements. This installation should be entrusted to duly qualified personnel where required by law.

STEP-BY-STEP INSTALLATION (Note: Please read all instructions before installing)

1. Rough in framing opening following the recommended dimensions located in (Section A: Framing).
 2. Allow 8" of service cable for connecting power supply wire to junction box on fireplace when installing before finishing wall. Allow up to 4 feet of service cable for connecting power supply wire to junction box on fireplace when installing after finishing wall. Remove the outer jacket and strip the individual conductors 1/2" from the end.
 3. Loosen the screw securing the junction box cover and remove the cover.
 4. Remove knockouts if necessary or use the provided cable clamp.
 5. Place unit in position in the framed opening, level with shims if necessary and attach unit to frame using mounting flanges provided (see figure 3 on page 3).
6. Unit is factory wired for 208/240 volt power supply (**see figure 1 on page 3**). If 120 volt operation is required, slide the switch and reconfigure the wiring (**see figure 2 on page 3**). Wires L1, L2, N & G are attached to the rear of the junction box cable clamp for easy access.
7. Wire a dedicated, properly fused circuit with a 15amp rating for the appropriate voltage (120, 208/240). (**see Section C for factory setting wiring**)
 8. Make wall switch and or wall mounted thermostat connections as outlined in Section D: Wiring.
 9. Place all connectors inside the unit and secure the junction box cover to unit. Ensure that the cable clamp grips only the jacket of service cable, thermostat and if applicable wall switch lines.

SECTION A: FRAMING

Optiflame Dimensions

MODEL	A	B	C	D	E	F	G	H	I	J	K	L
BF33ST/DX	15.0"	33.5"	29.5"	23.0"	14.3"	29.6"	32.8"	18.8"	28.5"	48.0"	34.0"	34.0"
BF39ST/DX	16.0"	39.5"	33.5"	26.6"	15.3"	36.0"	38.7"	22.8"	32.7"	54.0"	38.0"	38.0"
BF45ST/DX	16.0"	45.5"	33.5"	26.6"	15.3"	42.0"	44.7"	22.8"	32.7"	60.0"	42.0"	42.0"

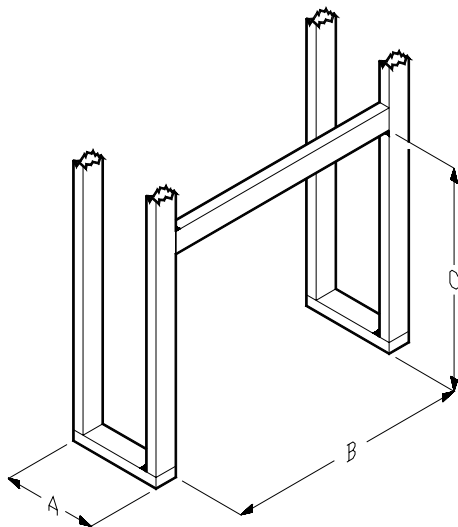

Rough-in framing dimensions

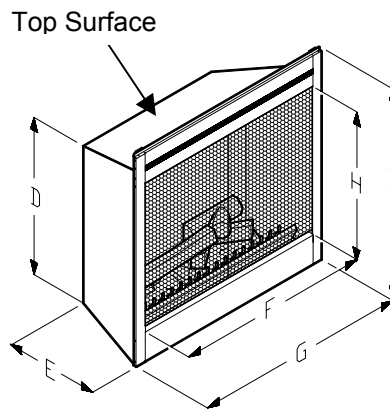

Firebox dimensions

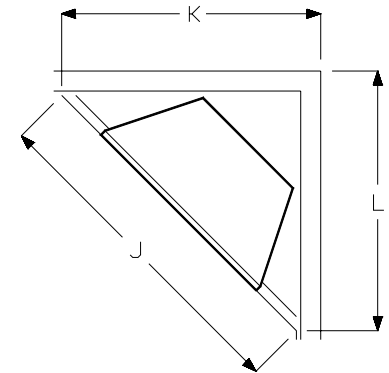

Rough-in corner framing

This fireplace is a zero clearance design. No combustibles can be placed on the top surface of the fireplace. Combustibles may be installed to the edge of the unit. Four mounting flanges on the sides of the unit are provided to facilitate installation. Insulation and vapor barrier should be placed a minimum of 2 inches from the unit.

SECTION B: RECOMMENDED POWER SUPPLY WIRE SPECIFICATIONS

For 120 volt installations use two conductor, non-metallic sheath cable with ground wire (3 wires total) for the incoming power supply on fireplace inserts. Use the appropriate wire to meet local and national electrical codes for rated power consumption.

For 208 / 240 volt installations use three conductor, non-metallic sheath cable with ground wire (4 wires total) for the incoming power supply on fireplace inserts. Use the appropriate wire to meet local and national electrical codes for rated power consumption.

Two conductor, non-metallic sheath cable with ground wire (3 wires total) is recommended for installation of a wall mounted thermostat and/or wall switch for use on fireplace inserts. Use appropriate wire to meet local and national electrical codes for rated power consumption. All wire gauges should match the recommended wire sizes shown below.

RECOMMENDED WIRE AND FUSING REQUIREMENTS

VOLTS	WIRE GAUGE	FUSE RATING
120 VOLT	12 GAUGE	15 AMP
208 VOLT	12 GAUGE	15 AMP
240 VOLT	12 GAUGE	15 AMP

VOLTAGE SELECTOR SWITCH LOCATION

IMPORTANT:

Ensure that the incoming power supply voltage matches the setting of the voltage selector switch.

NOTE:

The voltage selector switch is located inside the exhaust panel on the top right hand corner.

CAUTION:

When changing the voltage selector switch from 240 volts to 120 volts ensure that the power supply is turned off.

NOTE:

Carefully insert a flat headed screwdriver inside the exhaust panel to change the switch from 240 volts (230 position) to 120 volts (115 position).

When wiring the unit for 208 / 240 volts the voltage selector switch should be in the 230 volt position. (see figure 1)

When wiring the unit for 120 volts the voltage selector switch should be in the 115 volt position. (see figure 2)

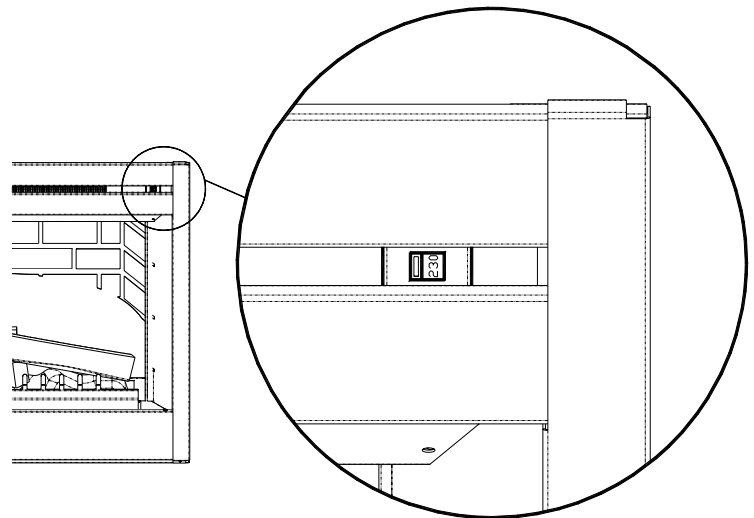

FIGURE 1

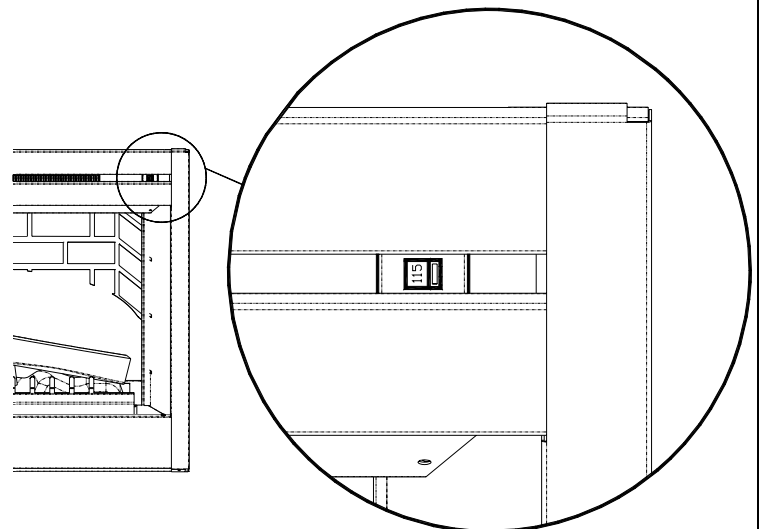

FIGURE 2

MOUNTING FLANGES

There are two mounting flanges located on each side of the fireplace insert.

Bend tabs and mount to framing using suitable hardware.

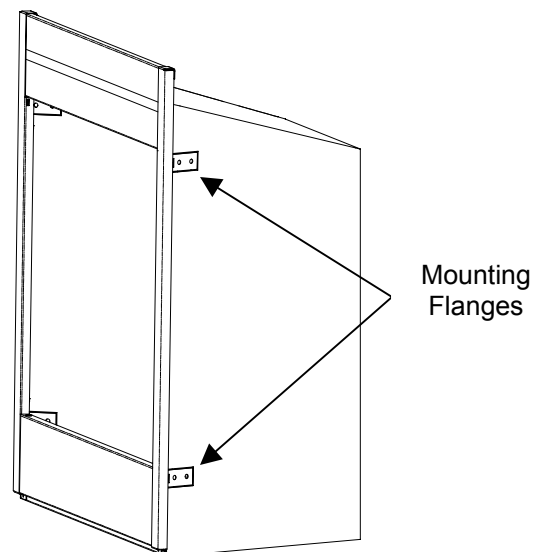

FIGURE 3

SECTION C: FACTORY SETTING WIRING (WITHOUT MAIN POWER WALL SWITCH)

IMPORTANT:

The unit is factory configured for 208/240 volt operation

NOTE:

Use 3 conductor wire with ground (4 wires total) from the power supply (breaker panel) to the junction box on the unit.

NOTE:

All wiring must be completed prior to installing the unit.

NOTE:

Ensure that the voltage selector switch is in the proper position for the required supply voltage prior to connecting the unit to the power supply.

240 VOLT INSTALLATION

1. Locate the voltage selector switch inside the exhaust panel on the top right hand corner of the unit. (see figure 1 on page 3)

2. Ensure that the switch is in the 240 volt position. (230 is printed on switch)

3. Loosen the screw securing the junction box cover and remove the cover.
4. Remove the knockouts (if necessary) or use the provided cable clamp.
5. Pull out the four wires marked L1, L2, N, and G.
6. Connect the black L1 wire from the unit to the black L1 from the power supply.
7. Connect the red L2 wire from the unit to the red L2 from the power supply.
8. Connect the white N wire from the unit to the to the white neutral from the power supply.
9. Connect the green ground wire from the unit to the ground from the power supply.
10. Ensure that all connections are tight.
11. Insert all the wiring back into the unit and secure with a cable clamp.

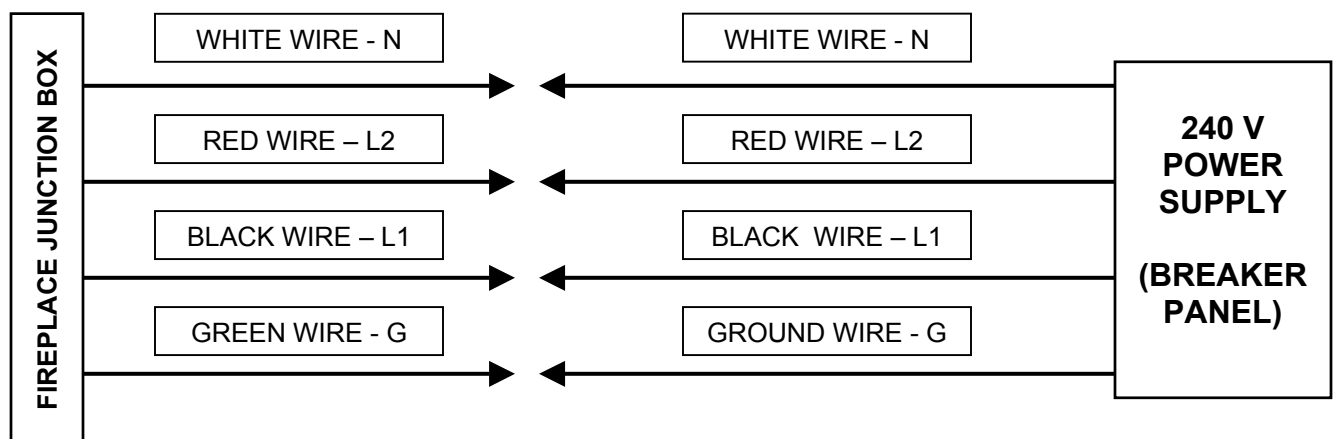

SECTION C: FACTORY SETTING WIRING (WITHOUT MAIN POWER WALL SWITCH)

IMPORTANT:

The unit is factory configured for 208/240 volt operation

NOTE:

Use 2 conductor wire with ground (3 wires total) from the power supply (breaker panel) to the junction box on the unit.

NOTE:

All wiring must be completed prior to installing the unit.

NOTE:

Ensure that the voltage selector switch is in the proper position for the required supply voltage prior to connecting the unit to the power supply.

120 VOLT INSTALLATION

1. Locate the voltage selector switch inside the exhaust panel on the top right hand corner of the unit. (see figure 2 on page 3)

2. Flip the switch from 240 volt to 120 volt configuration. (230 and 115 is printed on switch)

3. Loosen the screw securing the junction box cover and remove the cover.
4. Remove the knockouts (if necessary) or use the provided cable clamp.
5. Pull out the four wires marked L1, L2, N, and G.
6. Connect the black L1 wire from the unit to the black L1 from the power supply.
7. Connect the red L2 and white N wire from the unit to the white neutral wire from the power supply.
8. Connect the green ground wire from the unit to the ground from the power supply.
9. When the unit has been configured for the appropriate power supply voltage, ensure that all connections are tight.
10. Insert all the wiring back into the unit and secure with a cable clamp.

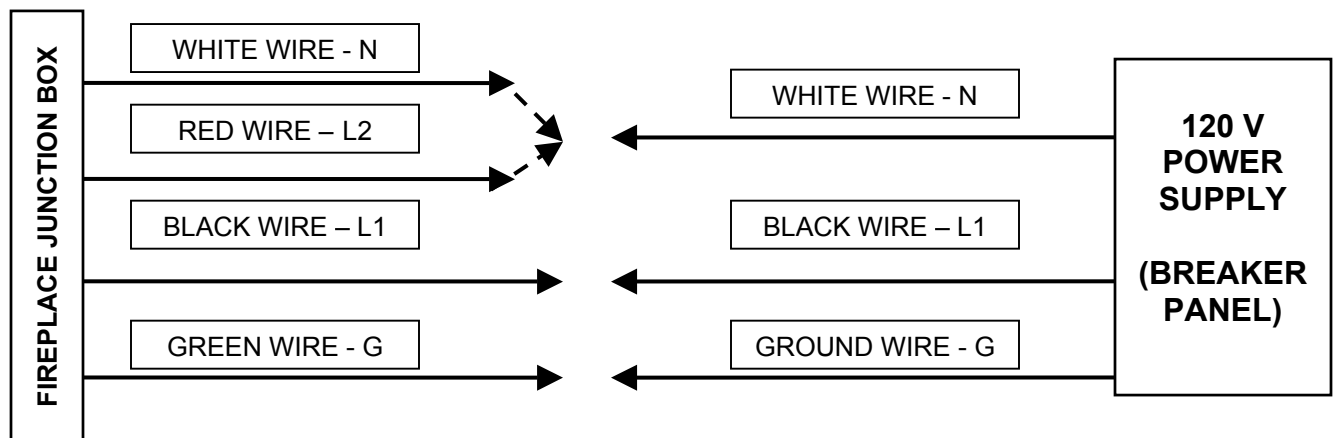

SECTION D: MAIN POWER WALL SWITCH WIRING OPTIONS

MAIN POWER WALL SWITCH WIRING FOR 240 VOLT

NOTE:

This option **should not** be used with the remote control kit.

NOTE:

Before installing the unit you must have the following wires installed:

1. A 3 conductor wire with ground (4 wires total) from the power supply panel to the main switch wall box.
2. A 3 conductor wire with ground (4 wires total) from the main switch wall box to the junction box on the unit.

NOTE:

Use a double pole, single throw (on/off) wall switch that is rated for a minimum of 15 amps.

240 VOLT INSTALLATIONS

1. Locate the voltage selector switch inside the exhaust panel on the top right hand corner of the unit. (see figure 1 on page 3)

2. Ensure that the switch is in the 240 volt position. (230 is printed on switch)

3. Loosen the screw securing the junction box cover and remove the cover.
4. Remove the knockouts (if necessary) or use the provided cable clamp.
5. Pull out the four wires marked L1, L2, N, and G. (black, red, white and green)
6. Connect the (black) L1 wire from the unit to the (black) L1 wire from the main power wall switch by using a wire connector (not supplied).
7. Connect other end of (black) L1 wire from the main power wall switch to the L1 terminal of the main power wall switch.
8. Connect the (red) L2 wire from the unit to the (red) L2 wire from the main power wall switch by using a wire connector (not supplied).
9. Connect the other end of the (red) L2 wire from the main power wall switch to the L2 terminal of the main power wall switch.
10. Connect the (white) Neutral wire from the unit to the (white) Neutral wire from the main power wall switch by using a wire connector (not supplied).
11. Connect the (green) Ground wire from the unit to the (green) Ground wire from the main power wall switch by using a wire connector (not supplied).
12. Connect the (red or black) L1 wire from the power supply to the L1 terminal of the main power wall switch.
13. Connect the (black) L2 wire from the power supply to the L2 terminal of the main power wall switch.
14. Connect the (white) Neutral wire from the power supply to the remaining (white) Neutral wire from the unit by using a wire connector.
15. Secure the 2 remaining (green) Ground wires with a ground screw in the main switch wall box.
16. Ensure that all connections are tight.
17. Insert all the wiring of the main power wall switch into the main switch wall box.
18. Insert all the wiring back into the unit and secure with a cable clamp.

240 VOLT MAIN WALL SWITCH WIRING DIAGRAM

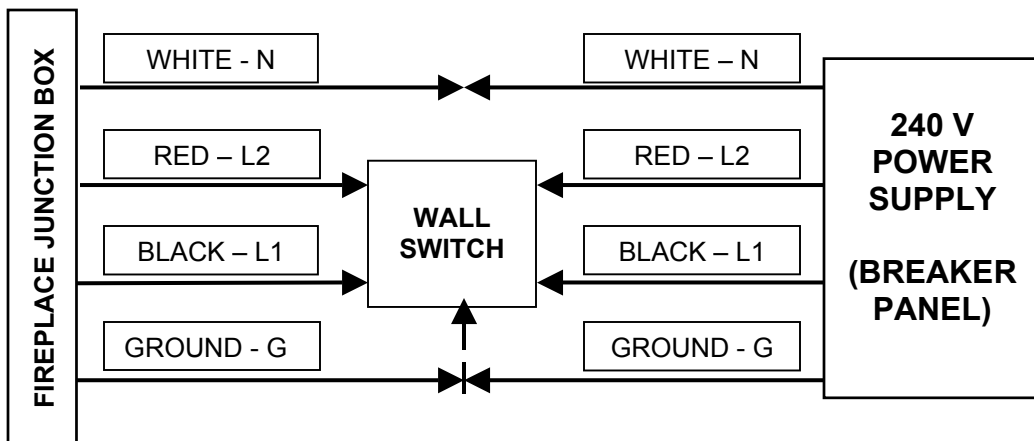
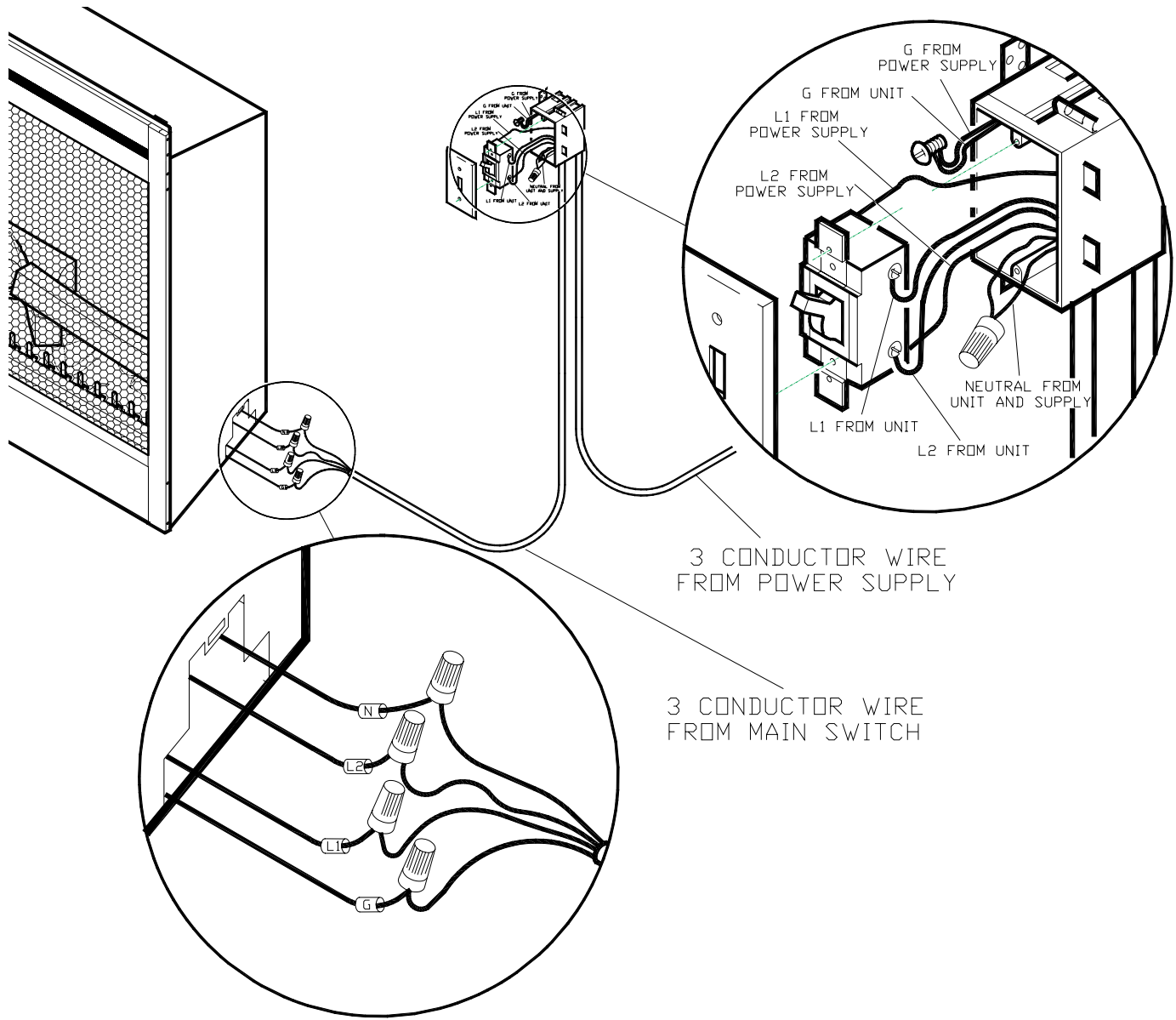

MAIN POWER WALL SWITCH WIRING FOR 120 VOLT

NOTE:

This option **should not** be used with the remote control kit.

NOTE:

Before installing the unit have the following wires installed:

1. A 2 conductor wire with ground (3 wires total) from the power supply panel to the main switch wall box.
2. A 2 conductor wire with ground (3 wires total) from the main switch wall box to the junction box on the unit.

NOTE:

Use a single pole, single throw (on/off) wall switch that is rated for a minimum of 15 amps.

120 VOLT INSTALLATIONS

1. Locate the voltage selector switch inside the exhaust panel on the top right hand corner of the unit. (see figure 2 on page 3)

2. Ensure that the switch is in the 120 volt position. (115 is printed on switch)

3. Loosen the screw securing the junction box cover and remove the cover.
4. Remove the knockouts (if necessary) or use the provided cable clamp.
5. Pull out the four wires marked L1, L2, N, and G. (black, red, white and green)
6. Connect the (black) L1 wire from the unit to the (black) L1 wire from the main power wall switch using a wire connector (not supplied).
7. Connect the other end of the (black) L1 wire to the L1 terminal of the main power wall switch.
8. Connect the (red) L2 wire from the unit and the (white) Neutral wire from the unit to the (white) Neutral wire of the main power wall switch by using a wire connector (not supplied).
9. Connect the other end of the (white) Neutral wire to the (white) Neutral wire from the power supply panel by using a wire connector (not supplied).
10. Connect the (green) Ground wire from the unit to the (green) Ground wire of the main power wall switch by using a wire connector (not supplied).
11. Connect the (black) L1 wire from the power supply to the L1 terminal of the main power wall switch.
12. Secure the 2 remaining (green) Ground wires with a ground screw in the main switch wall box.
13. Ensure that all connections are tight.
14. Insert all the wiring of the main power wall switch into the main switch wall box.
15. Insert all the wiring back into the unit and secure with a cable clamp.

120 VOLT MAIN WALL SWITCH WIRING DIAGRAM

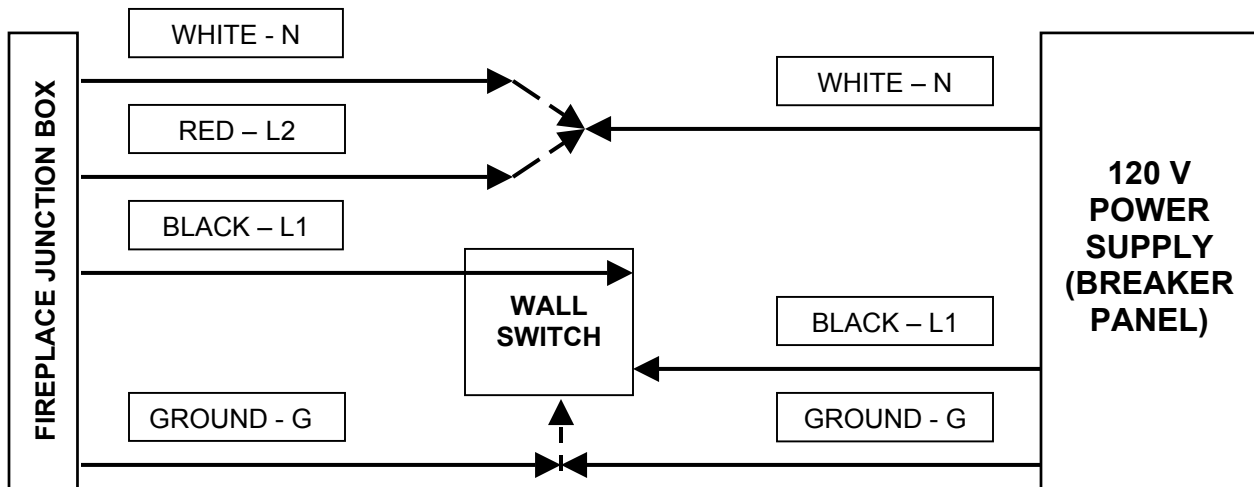
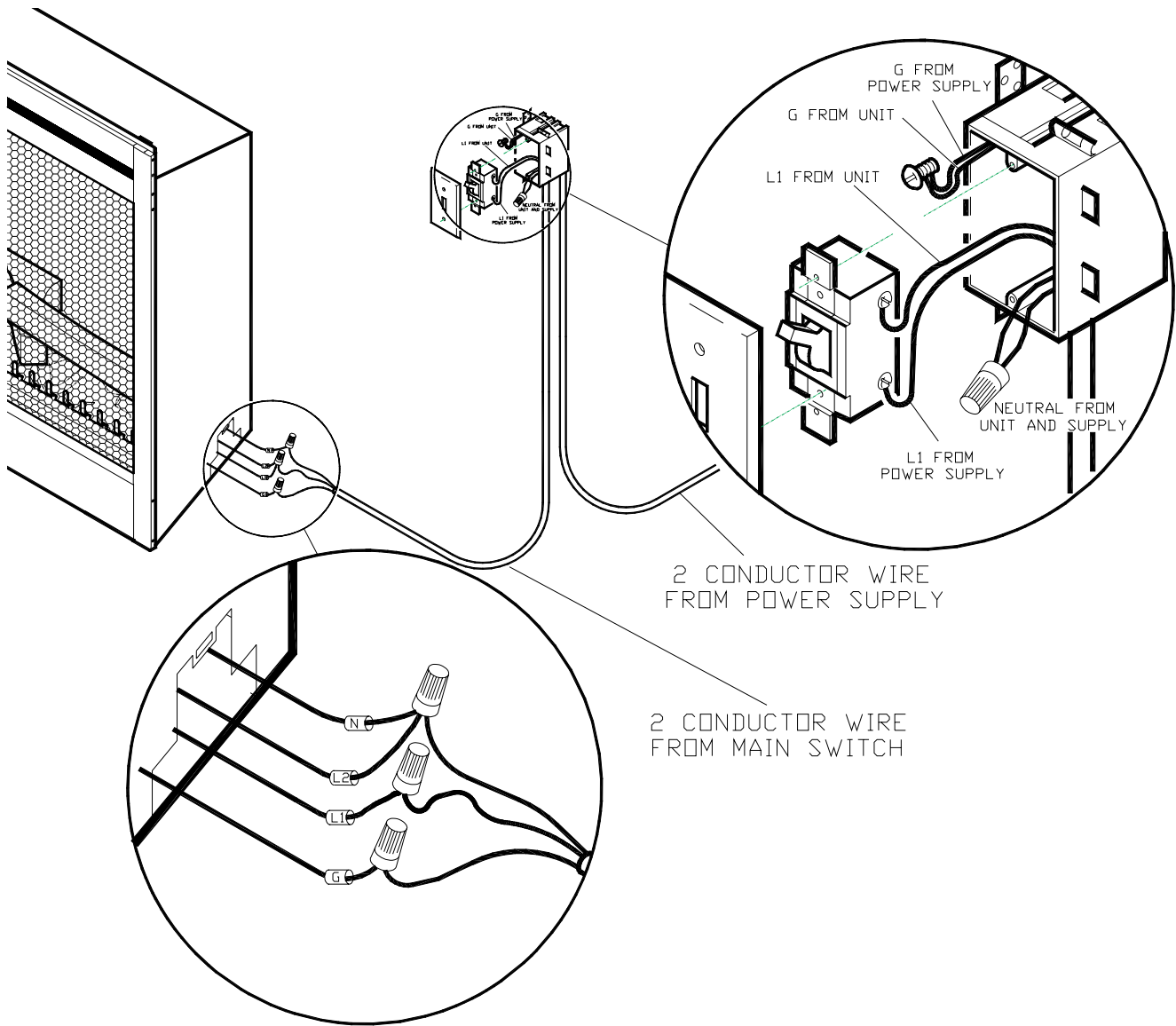

SECTION E: HEATER WALL SWITCH AND WALL THERMOSTAT WIRING OPTIONS

HEATER WALL SWITCH WIRING FOR 120/240 VOLT

NOTE:

Before installing the unit complete the following:

1. Install main power connection with appropriate voltage as per Section C or Section D.
2. Install a 2 conductor wire with ground (3 wires total) from the heater switch wall box to the junction box on the unit.

NOTE:

Use a heater wall switch (on/off) that is rated for a minimum of 15 amps.

120 / 240 VOLT INSTALLATIONS

1. Loosen the screw securing the junction box cover and remove the cover.
2. Remove the knockouts (if necessary) or use the provided cable clamp.
3. Pull out the three wires marked 1, 2, and G. (red, red, and green)
4. Remove the wire connector and separate the wires marked 1 and 2.
5. Connect the (red) 1 wire from the unit to the (black) L1 wire from the heater wall switch by using a wire connector (not supplied).
6. Connect the other end of (black) L1 wire from the heater wall switch to the L1 terminal of the heater wall switch.
7. Connect the (red) 2 wire from the unit to the (white) Neutral wire from the heater wall switch using a wire connector (not supplied).
8. Connect the other end of the (white) Neutral wire from the heater wall switch to the L2 terminal of the heater wall switch.
9. Connect the (green) Ground wire from the unit to the (green) Ground wire from the heater wall switch using a wire connector (not supplied).
10. Secure the one remaining (green) Ground wire with a ground screw in the heater switch wall box.
11. Ensure that all connections are tight.
12. Insert all the wiring of the heater wall switch into the heater switch wall box.
13. Insert all the wiring back into the unit and secure with a cable clamp.

HEATER WALL SWITCH WIRING DIAGRAM FOR 120/240 VOLT (SEE SECTION C OR SECTION D FOR MAIN POWER CONNECTION)

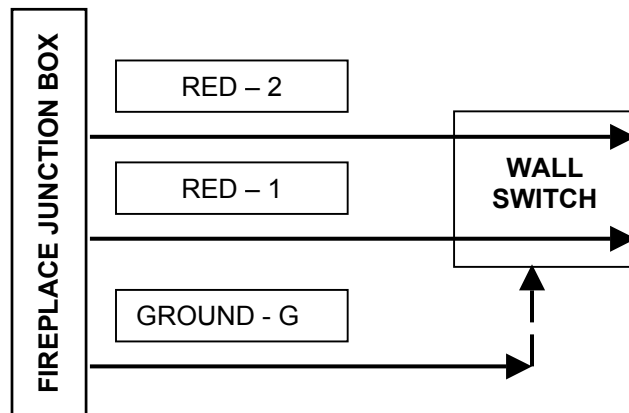
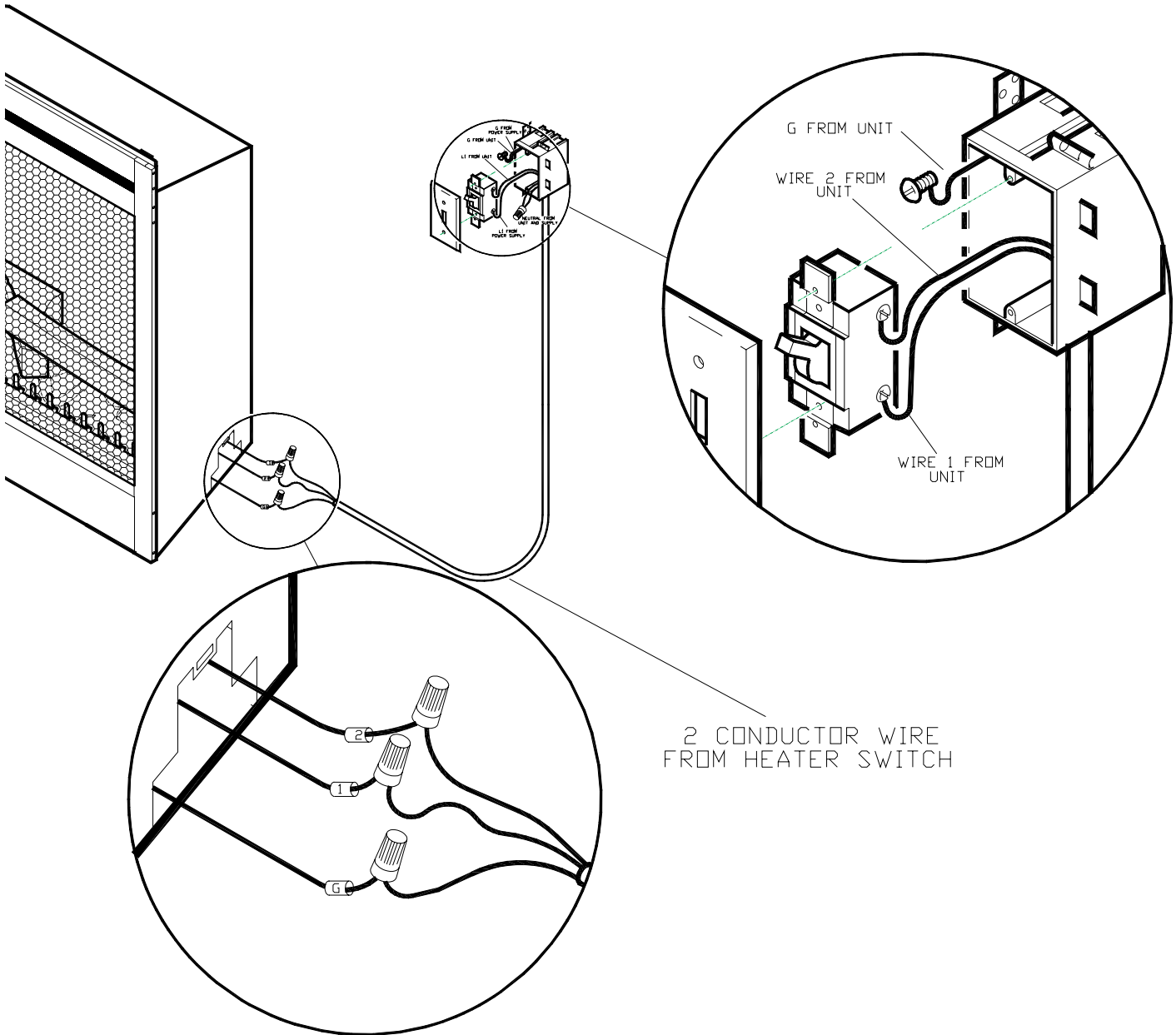

WALL MOUNTED THERMOSTAT WIRING FOR 120/240 VOLT

NOTE:

Before installing the unit complete the following:

1. Install main power connection with appropriate voltage as per Section C or Section D.
2. Install a 2 conductor wire with ground (3 wires total) from the heater switch wall box to the junction box on the unit.

NOTE:

Wiring of the thermostat must be completed prior to installing the unit.

NOTE:

The following installation instructions are for a single pole thermostat.

120 / 240VOLT INSTALLATIONS

1. Loosen the screw securing the junction box and remove the cover.
2. Remove the knockouts (if necessary) or use the provided cable clamp.
3. Pull out the three wires marked 1, 2, and G. (red, red, and green).
4. Remove the wire connector and separate the wires marked 1 & 2.
5. Connect the (red) 1 wire from the unit to the white (neutral) wire from the wall thermostat box by using a wire connector. (not supplied)
6. Connect the other end of the white (neutral) wire from the thermostat wall box to the red wire from the wall thermostat.
7. Connect the (red) 2 wire from the unit to the black wire from the thermostat wall box by using a wire connector. (not supplied)
8. Connect the other end of the black wire from the thermostat wall box to the black wire from the wall thermostat.
9. Connect the green (ground) wire from the unit to the green (ground) wire from the thermostat wall box by using a wire connector. (not supplied)
10. Connect the other end of the green (ground) wire from the thermostat wall box to the back plate of the wall mounted thermostat with a ground screw.
11. Ensure that all connections are tight.
12. Insert all the wiring of the wall mounted thermostat into the wall box.
13. Insert all the wiring back into the unit and secure with a cable clamp.

**WALL MOUNTED THERMOSTAT WIRING
DIAGRAM FOR 120/240 VOLT
(SEE SECTION C OR SECTION D FOR MAIN POWER CONNECTION)**

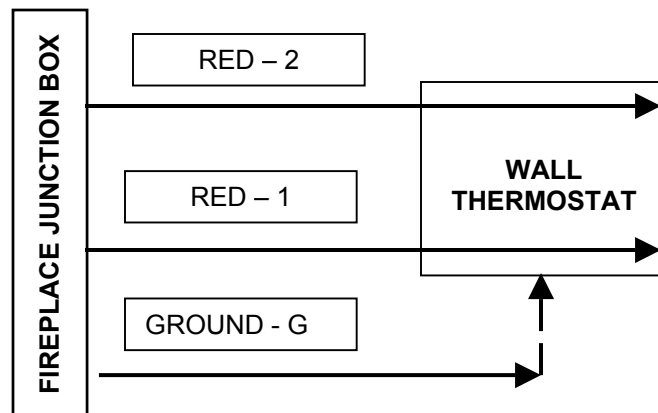
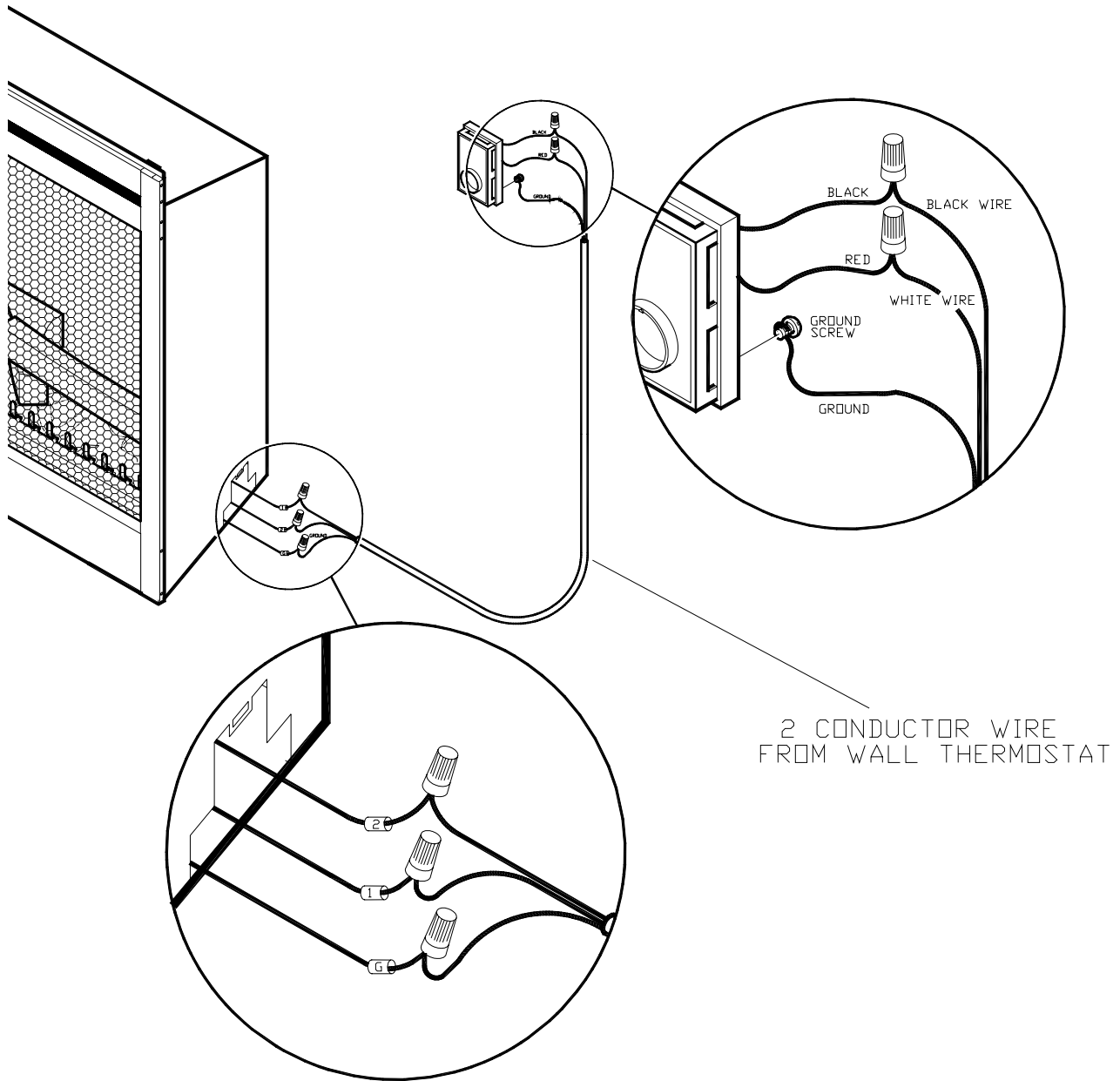

FLAME OVERRIDE SWITCH WIRING FOR 120/240 VOLT

NOTE:

The fireplace can be wired to have a wall switch operate the heater independent of the flame.

NOTE:

Before installing the unit complete the following:

1. Install main power connection with appropriate voltage as per Section C or Section D.
2. Install a 2 conductor wire with ground (3 wires total) from the flame override switch wall box to the junction box on the unit.

NOTE:

Use a wall switch (on/off) that is rated for a minimum of 15 amps.

120 / 240 VOLT INSTALLATIONS

1. Loosen the screw securing the junction box cover and remove the cover.
2. Remove the knockouts (if necessary) or use the provided cable clamp.
3. Pull out the three wires marked 3, 4, and G. (blue, blue, and green)
4. Remove the wire connector and separate the wires marked 3 and 4.
5. Connect the (blue) 3 wire from the unit to the (black) L1 wire from the flame override wall switch by using a wire connector (not supplied).
6. Connect the other end of the (black) L1 wire from the flame override wall switch to the L1 terminal of the flame override wall switch.
7. Connect the (blue) 4 wire from the unit to the (white) Neutral wire from the flame override wall switch using a wire connector (not supplied).
8. Connect the other end of the (white) Neutral wire from the flame override wall switch to the L2 terminal of the flame override wall switch.
9. Connect the (green) Ground wire from the unit to the (green) Ground wire from the flame override wall switch using a wire connector (not supplied).
10. Secure the one remaining (green) Ground wire with a ground screw in the flame override switch wall box.
11. Ensure that all connections are tight.
12. Insert all the wiring of the heater wall switch into the heater switch wall box.
13. Insert all the wiring back into the unit and secure with a cable clamp.

FLAME OVERRIDE WALL SWITCH WIRING DIAGRAM FOR 120/240 VOLT (SEE SECTION C OR SECTION D FOR MAIN POWER CONNECTION)

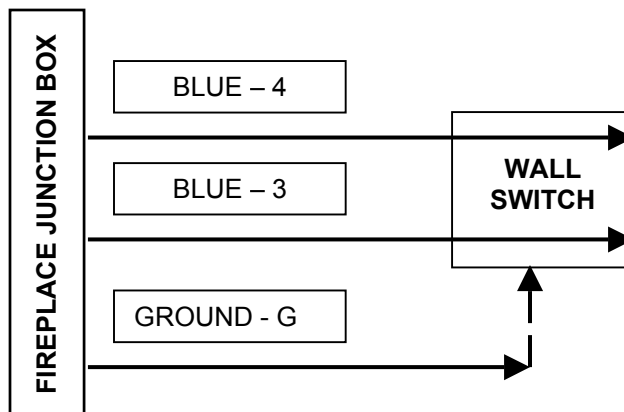
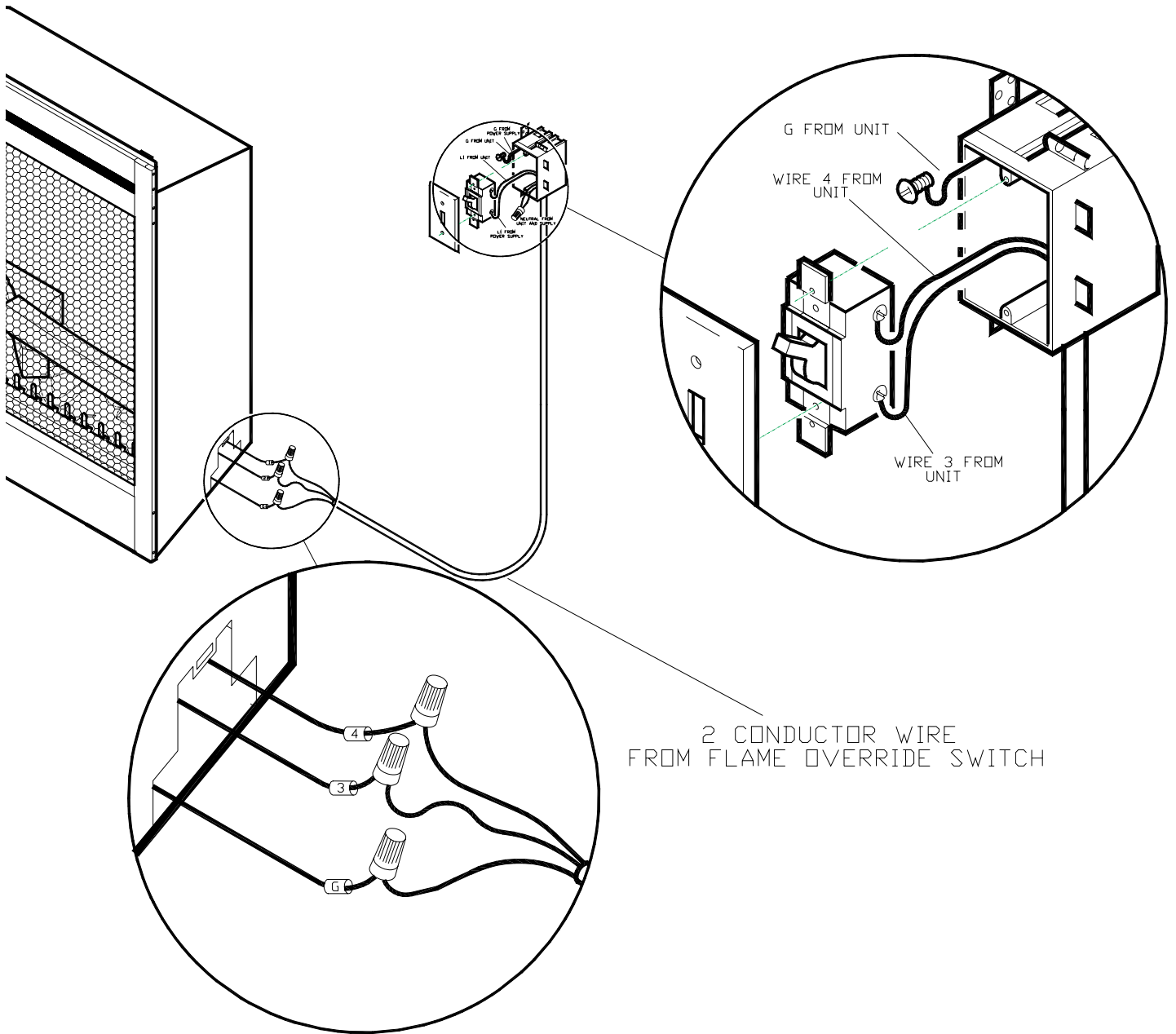

WIRING DIAGRAM LOWER SECTION

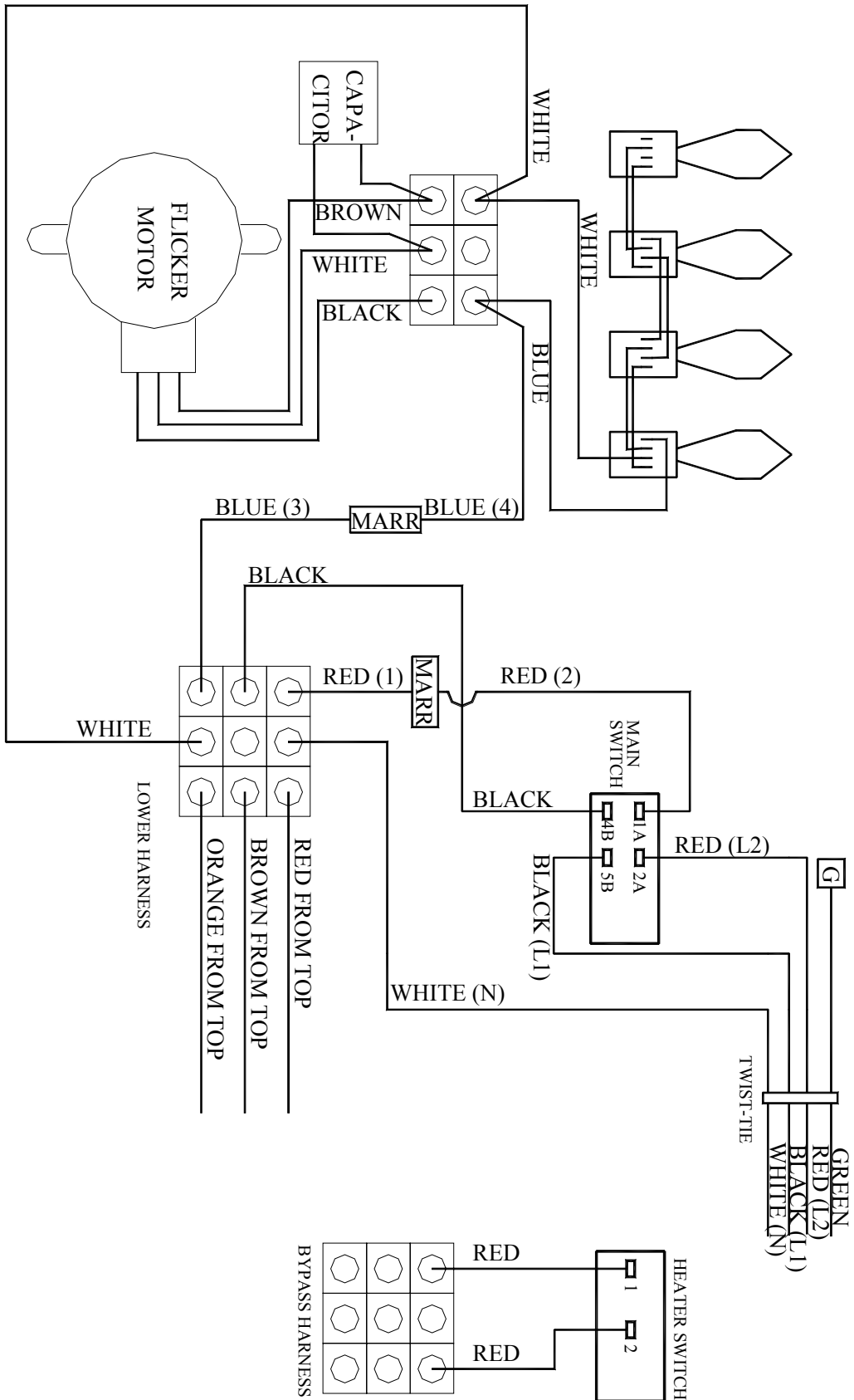

WIRING DIAGRAM UPPER SECTION

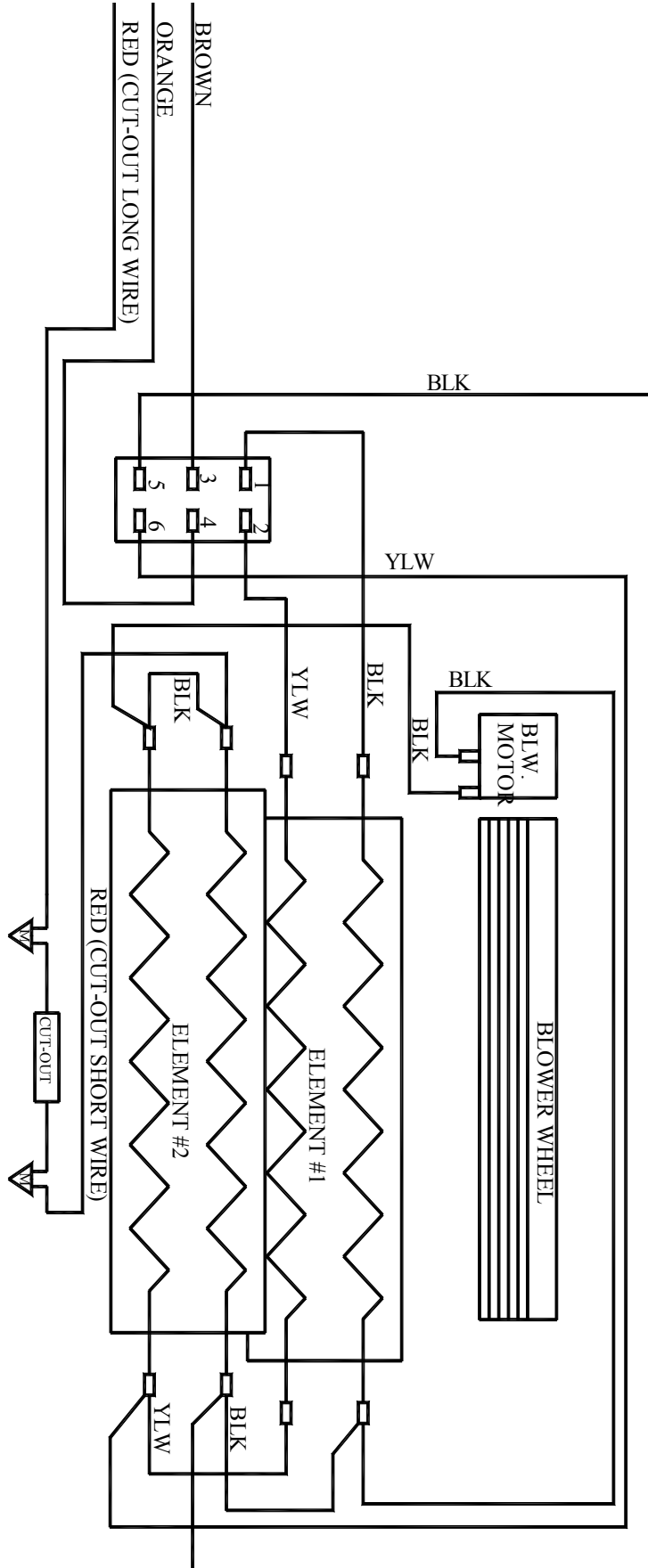

WIRING SCHEMATIC

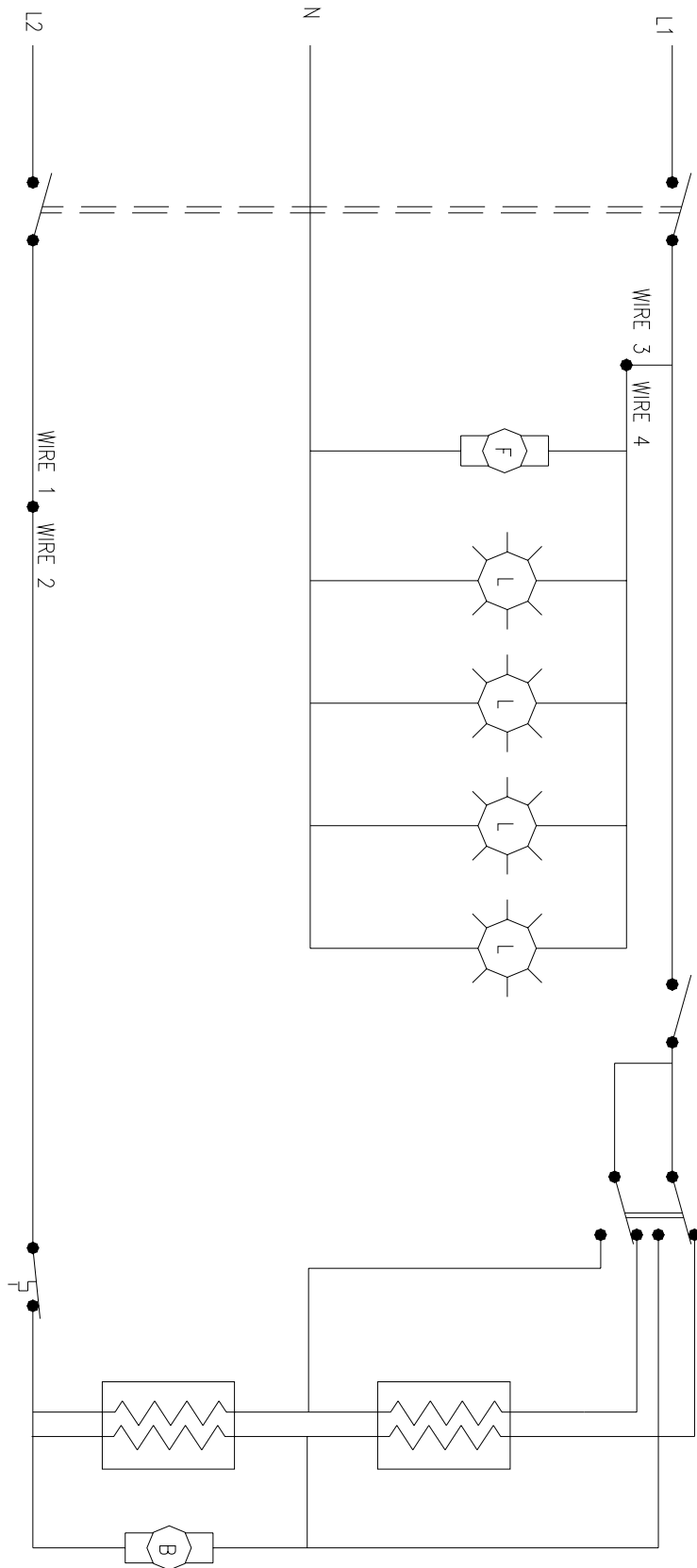

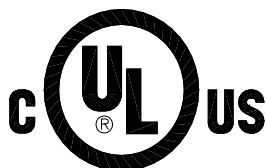

1-888-DIMPLEX
1-888-346-7539

 **Dimplex**
NORTH AMERICA LIMITED

1367 Industrial Road
Cambridge, Ontario
Canada, N1R 7G8

Approved for use in the United States and Canada